

Friendship Block Supplement

1993-1994

LINCOLN QUILTERS GUILD EVERYBODY IS A STAR

The theme for the 93-94 LQG Friendship Blocks, *Everybody Is A Star*, expresses our belief that each member of our guild is important. Each member's friendship is valued. And we want to encourage everybody to participate in the friendship block drawings. By providing the patterns for the whole quilting year at the September meeting, everyone should have the time and opportunity for assistance that they need. We are trying some fun and different things this year. There is an extra design for December, a little inspiration for the New Year in January, a continuity fabric in May's block and a special design strategy in March and May. We're also changing the philosophy somewhat from recent years. We may have fewer winners, but each will receive a substantial number of blocks - enough for a throw or even a bed size quilt! Templates as well as quick cut methods are provided for each pattern. As always, please prewash fabrics, use $\frac{1}{4}$ " seams, press seams towards darkest fabrics and measure carefully!!! You may submit as many blocks each month as you wish and will enter your name for each block you made, but you will only be eligible to win one set of blocks. If you have questions, please call Becky Haynes (483-7020) or Sheryl Jonas (423-1256). Let your stars shine!

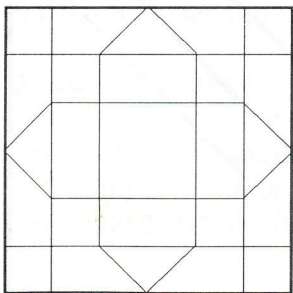

OCTOBER

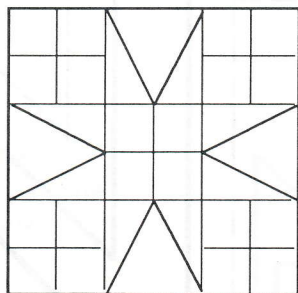

DECEMBER

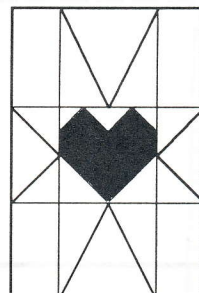

FEBRUARY

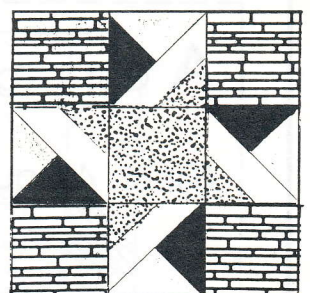

APRIL

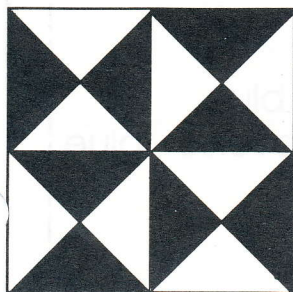

NOVEMBER

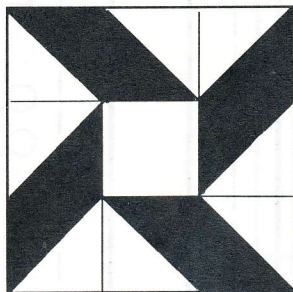

JANUARY

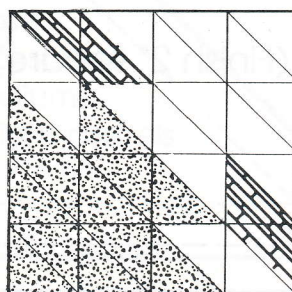

MARCH

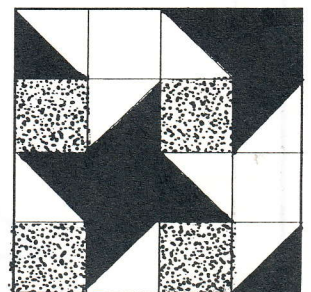

MAY

OCTOBER - Twinkle Twinkle Little Star (Oregon Trail)

Where's the star? In the fabric! And in the skies of those long nights on the Oregon Trail, the original name of this block, with enduring admiration for those pioneers of 150 years ago. Placement of the star fabric is the maker's choice, just follow the general color "recipe." Finished size is 12 inches square.

Quick Cut Method

- A - Cut (1) 4 1/2" square
- B - Cut (4) 2 1/2" x 4 1/2" rectangles
- C - Cut (8) 2 1/2" squares
- D - Cut (2) 3 3/4" squares and then cut diagonally to form triangles
- E - Use template (remember to cut 4 and cut 4 reverse)

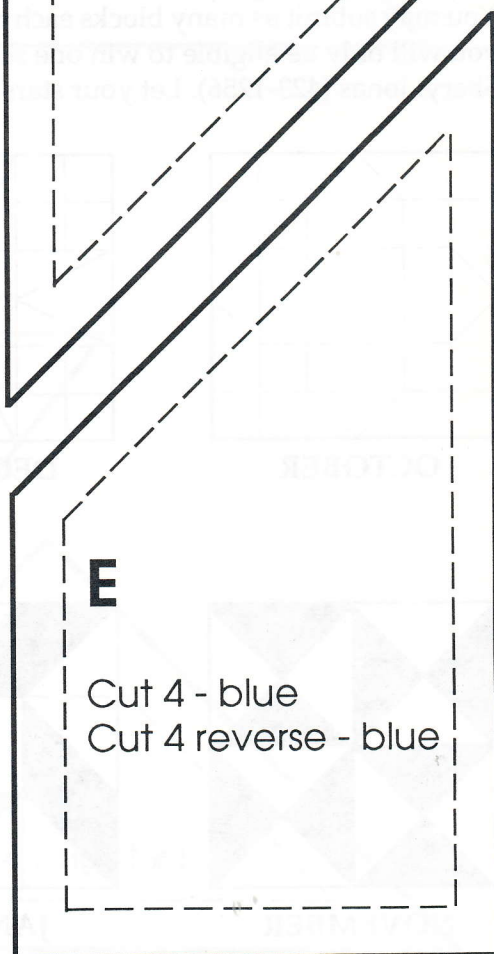
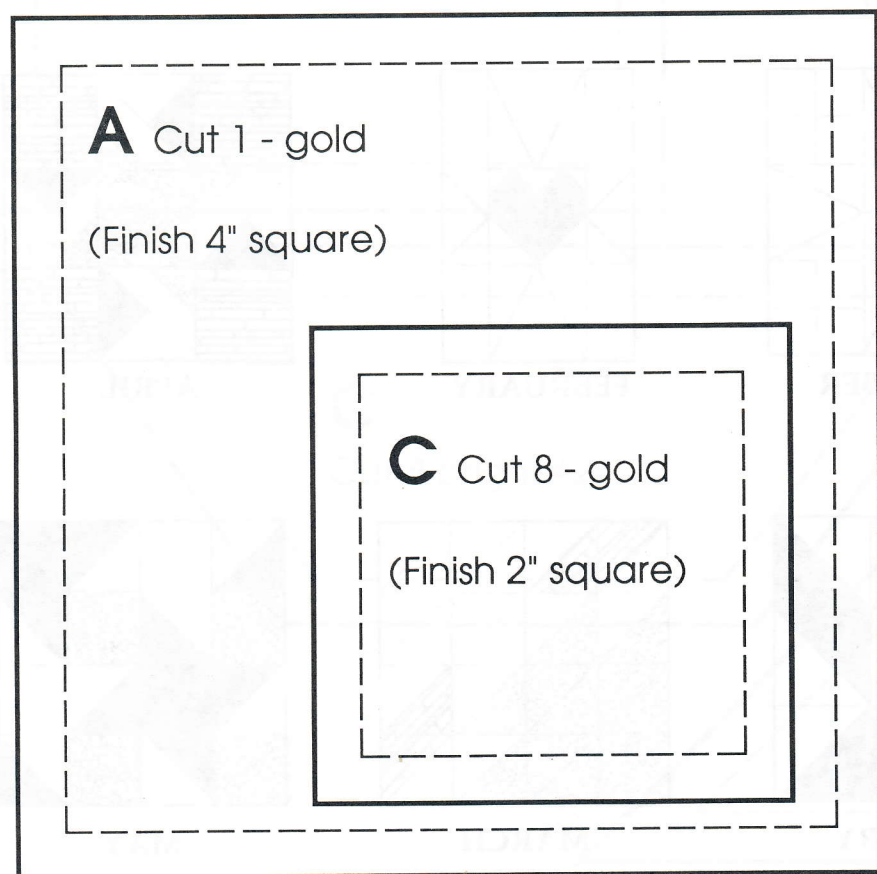
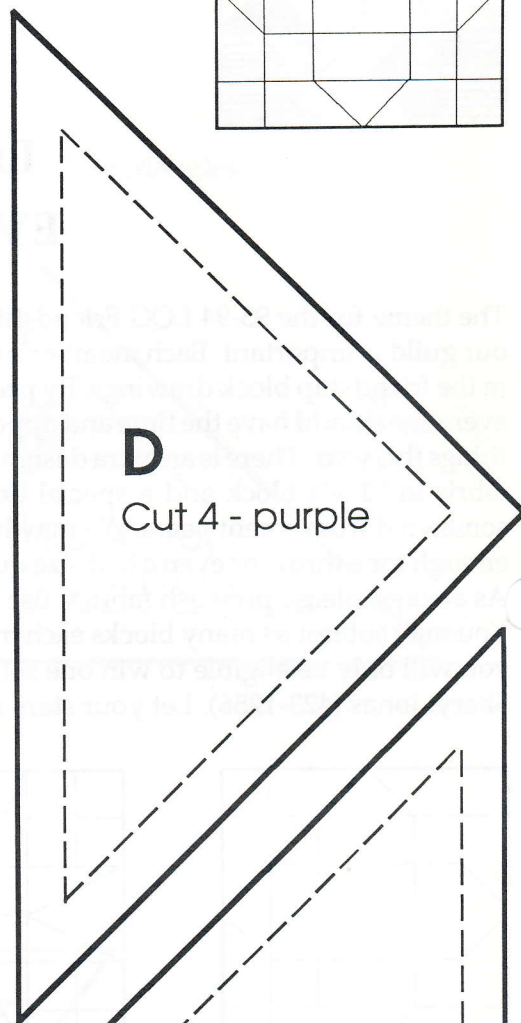
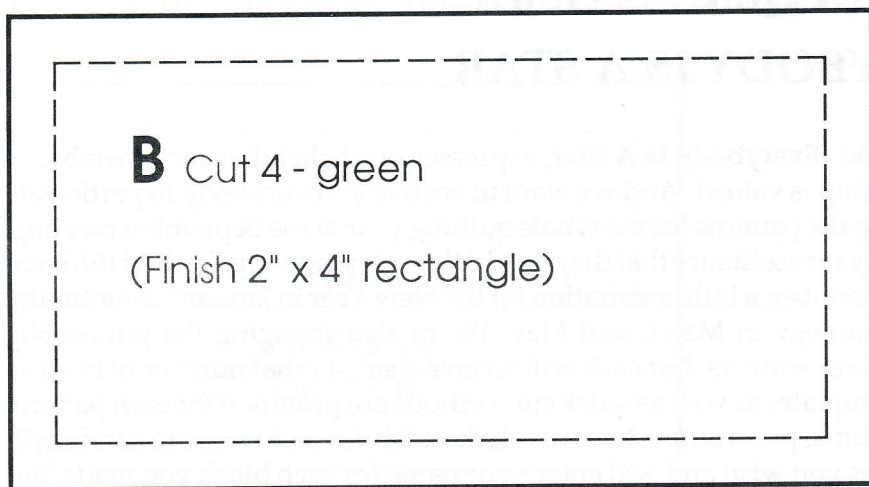
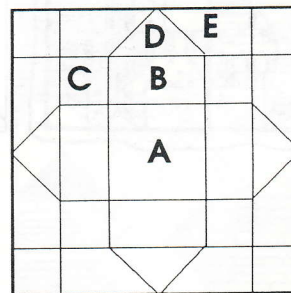

NOVEMBER - Big (Red) Dipper

This positive/negative effect is achieved using red and white (or off-white) prints. Remember that red can be stretched from bright, clear tones through rusty reds all the way to dark burgundies. This block is a great exercise in quarter-square triangles if you choose to use the quick cut method. Finished size is 8" square.

Quick Cut Method

Cut (2) red squares $5\frac{1}{4}$ "
Cut (2) white square $5\frac{1}{4}$ "

Stack squares on top of each other.

Cut these squares diagonally in both directions to yield 8 red and 8 white triangles

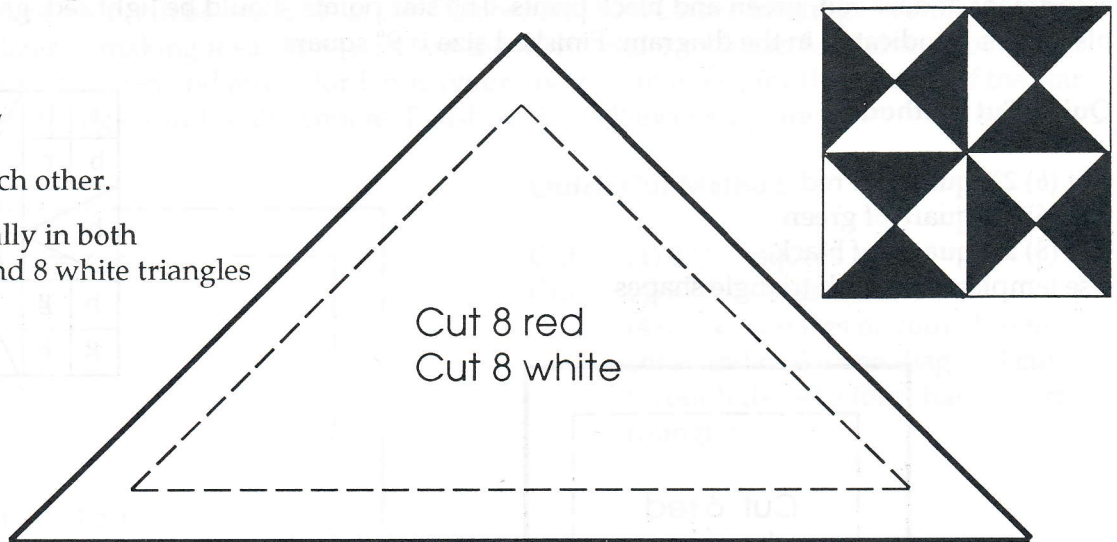
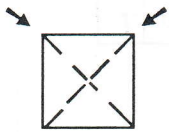

MARCH - Swinging on a Star

This block is done totally in half-square triangles. The star design becomes apparent through careful color placement when blocks are placed side by side. Use assorted medium-toned springtime colors in the shaded triangles and lighter pastels in the other triangles. Be sure to use medium-dark rose as indicated. This block finishes 8 inches square.

Quick Cut Method

Cut - (2) $2\frac{7}{8}$ " squares of rose
Cut - (6) $2\frac{7}{8}$ " squares of mediums
Cut - (2) $2\frac{7}{8}$ " squares pastels

Then cut all diagonally for
a total of 32 half square triangles

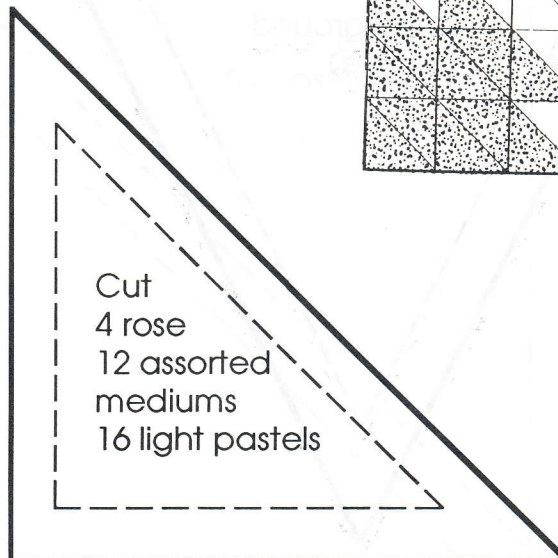
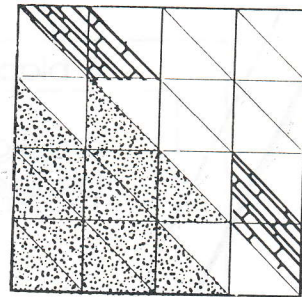

DECEMBER - Starry, Starry Night

This wonderful 54-40 or Fight variation is an extra holiday treat. Bring your block to the Andersen sisters' cookie exchange or mail to Becky Haynes by December 9 to be included in the drawing. (Be sure to include your name and phone number so I can call you with the happy news when you win!) Make this block using an assortment of dark red, green and black prints. The star points should be light red, green or black prints. Color placement is indicated in the diagram. Finished size is 9" square.

Quick Cut Method

- Cut (6) 2" squares of red
- Cut (6) 2" square of green
- Cut (8) 2" squares of black
- Use templates for both triangle shapes

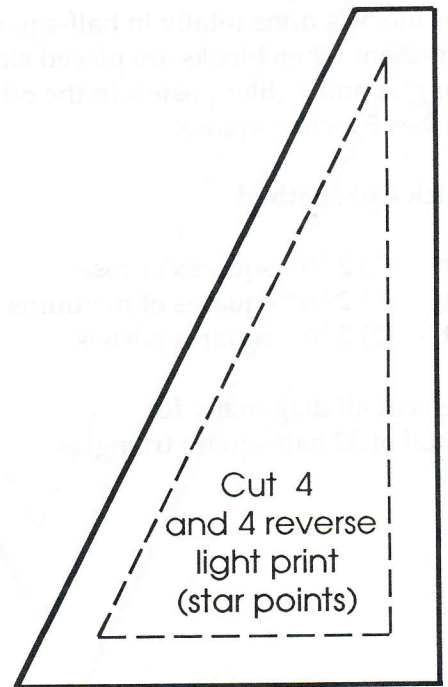
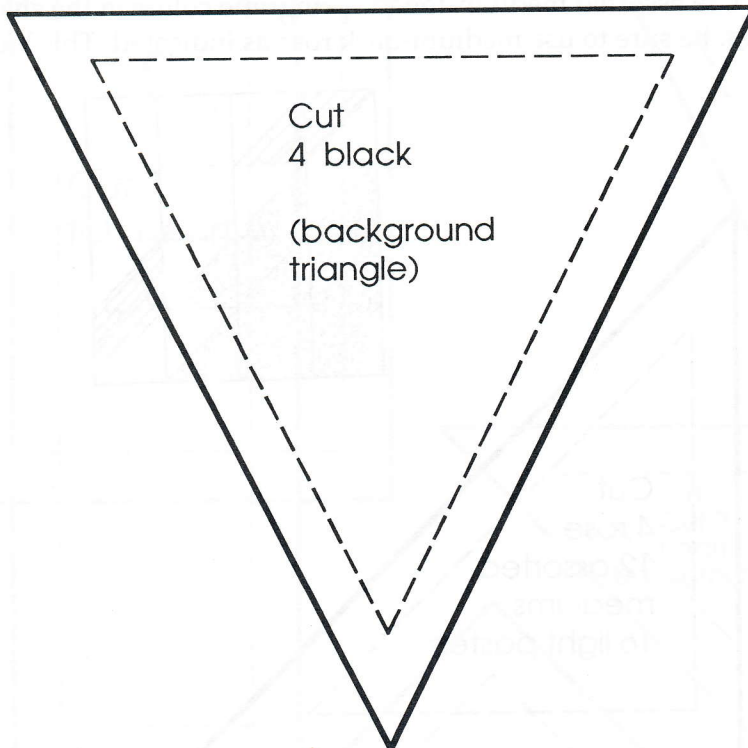
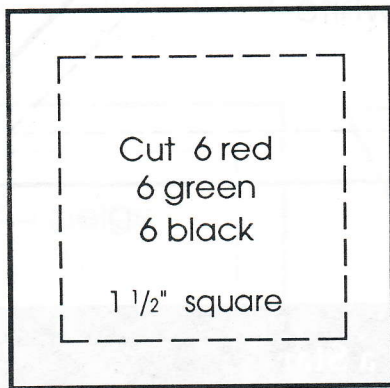
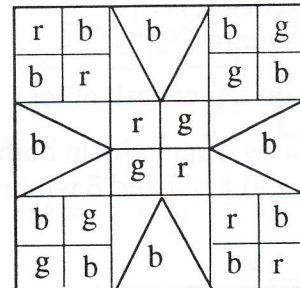

JANUARY - Eccentric Star

This month's block allows the maker to share her pearls of wisdom. Write your favorite saying on the fabric square in the middle of the block and embellish as desired. Be sure to use a permanent fabric marker such as a Pigma pen. Freezer paper will be available at the October and November meetings. Ironing this to the back of the fabric stabilizes it, making it easier to write on the fabric. Refer to Susan McKelvey's books for other tips and hints. Use any color pen and any color fabric (your favorite, maybe?) for the "arms" of the star. Use tans for the background triangles and center square. Finished size is 9 inches square.

Quick Cut Method

- Cut - (1) $3\frac{1}{2}$ " square
- Cut - (4) $3\frac{7}{8}$ " squares of tan and
(4) $3\frac{7}{8}$ " squares of your chosen color and make one diagonal cut through these to form half-square triangles.

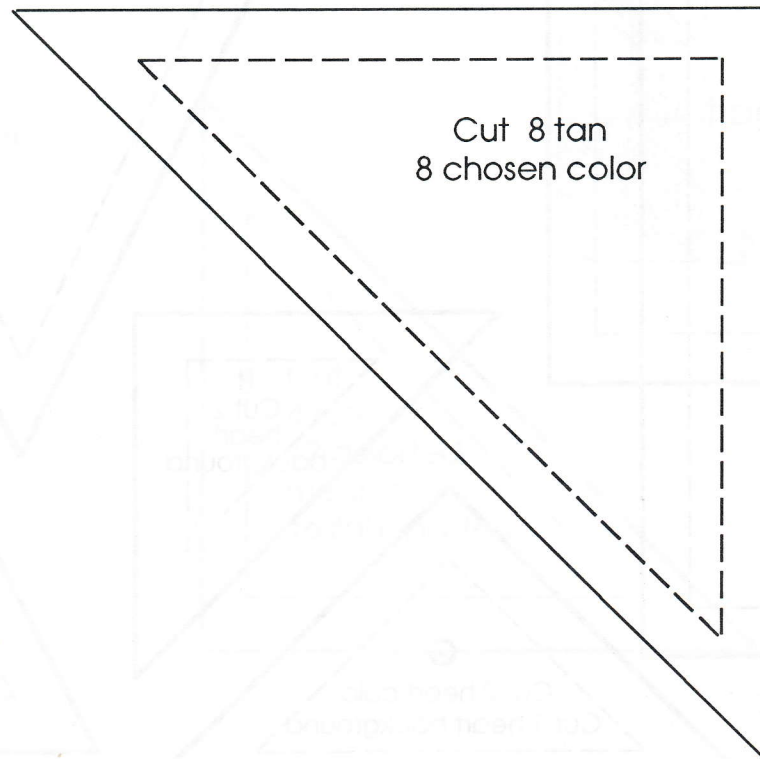
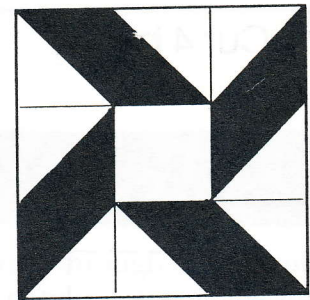
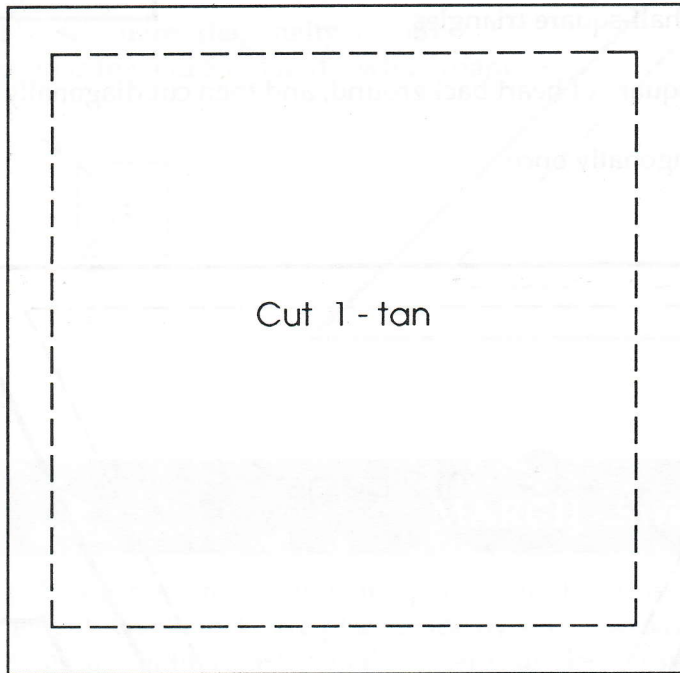

FEBRUARY - When You Wish Upon A Star

Give this "heart in a star" an old-time look by using dark reds, golds, browns or blues in any placement on a beige background. This is an elongated block which finishes to 8" x 12".

Quick Cut Method

A - Cut (4) $2\frac{1}{2}$ " x $4\frac{1}{2}$ " rectangles

B & C - Use templates

D - Cut (1) $3\frac{11}{16}$ " square of beige and (1) $3\frac{11}{16}$ " sq. of heart color, cut diagonally once

E - Cut (2) $2\frac{7}{8}$ " square of star point color and (1) $2\frac{7}{8}$ " sq of heart background and then cut diagonally to get half-square triangles

F - Cut (1) $1\frac{1}{2}$ " x $4\frac{1}{2}$ " rectangle

G - Cut (1) $2\frac{1}{4}$ " square of heart color and (1) $2\frac{1}{4}$ " square of heart background, and then cut diagonally to get half-square triangles

H - Cut (1) $1\frac{7}{8}$ " square of heart background, cut diagonally once

enlarged
diagram
of heart →

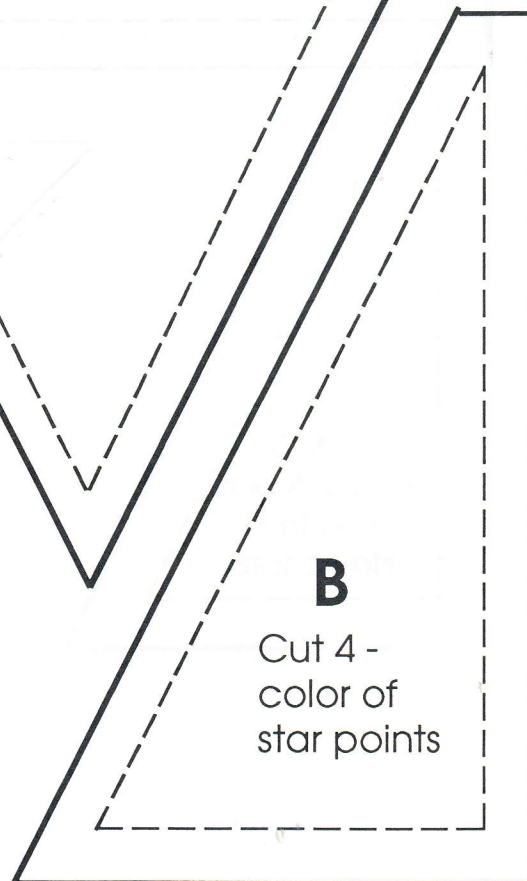
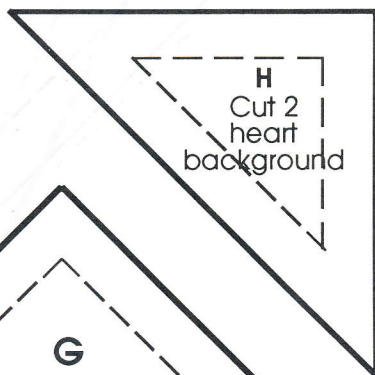
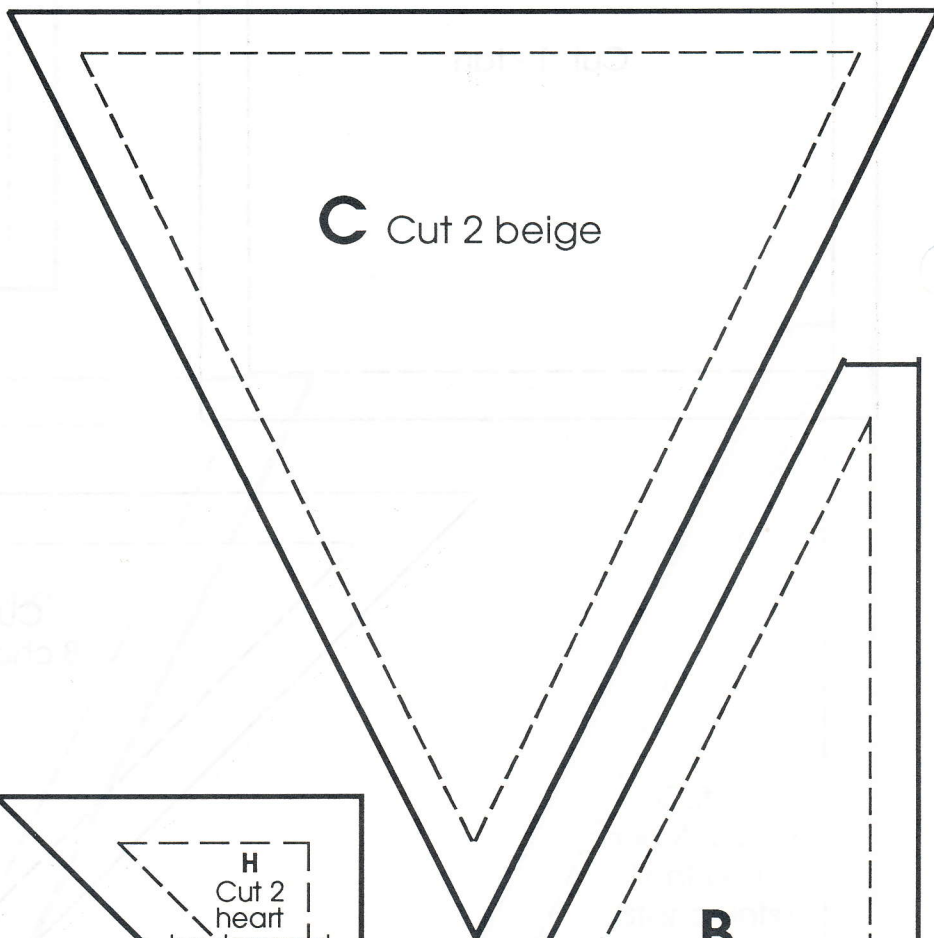
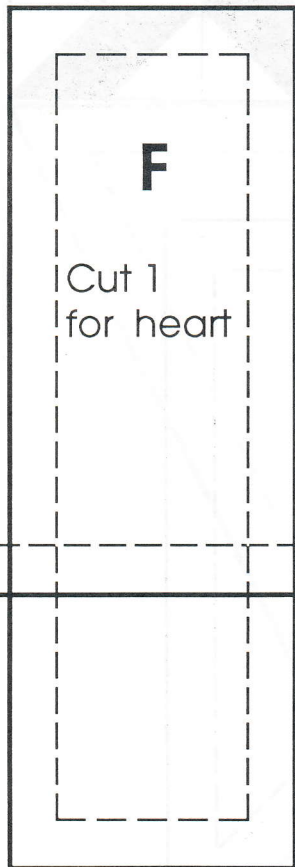
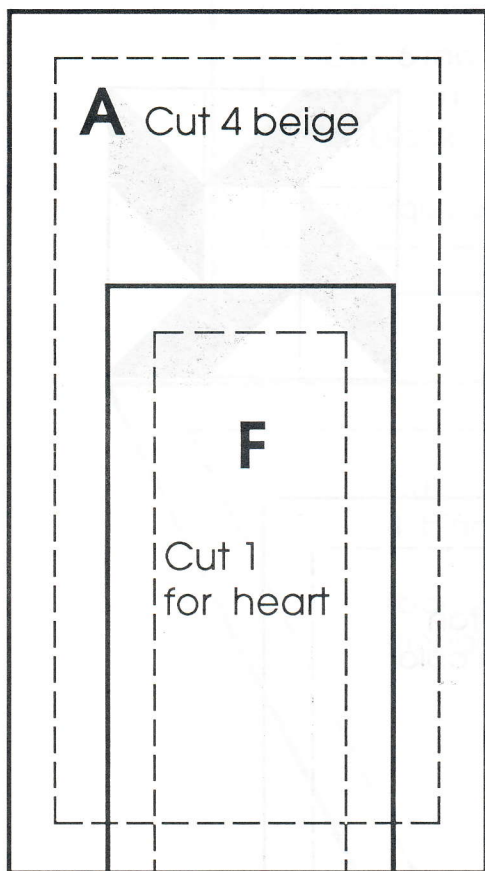
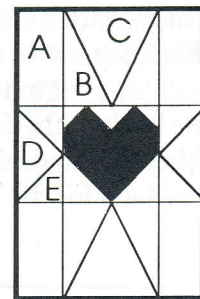
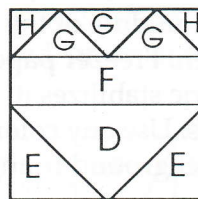

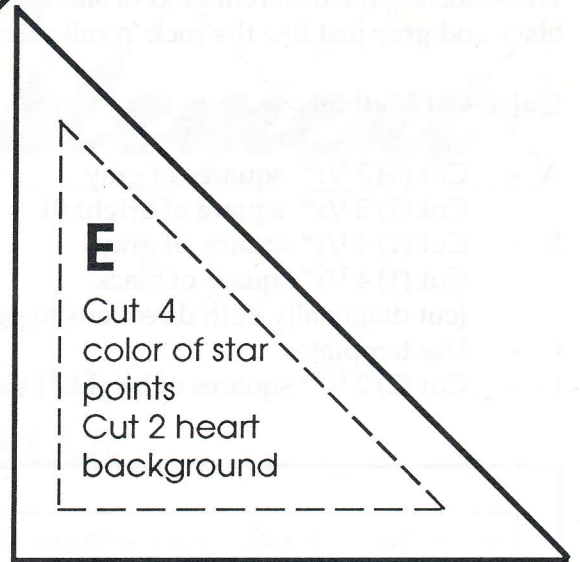
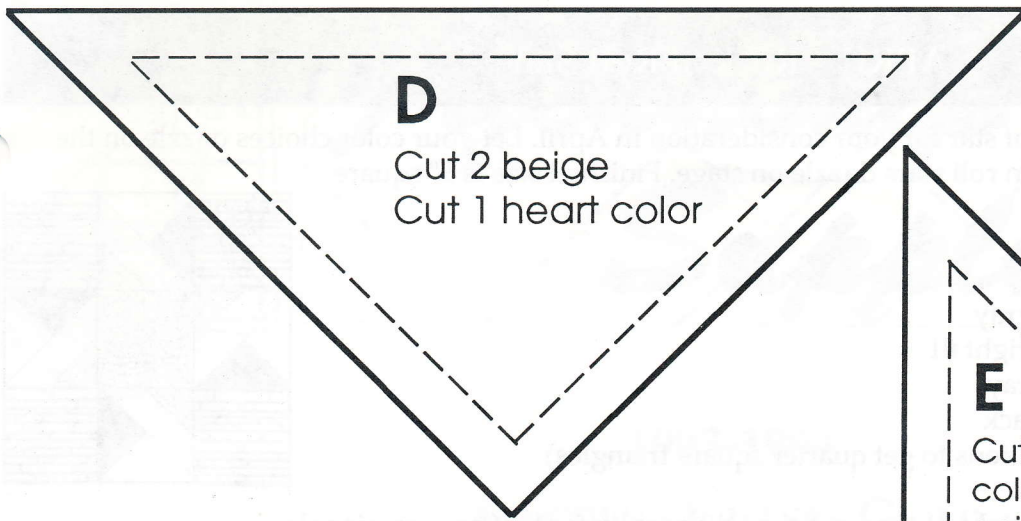

MAY - Milky Way

Once again, the overall star pattern doesn't emerge until the blocks are set together. We do need the help of our friends! To bring some continuity to this month's design, we will all use the same medium blue as the "background" for the dark blue and yellow/gold stars. You can get your pieces of this fabric at the Friendship Block table throughout the year. Finished size of this block is 10 inches square.

Quick Cut Method

- A - Cut (4) 3" square medium blue
Cut (2) 3" square dark blue
Cut (2) 3" square yellow/gold
- B - Cut (4) 3 3/8" square dark blue
Cut (4) 3 3/8" square yellow/gold

Then cut these once diagonally for half-square triangles

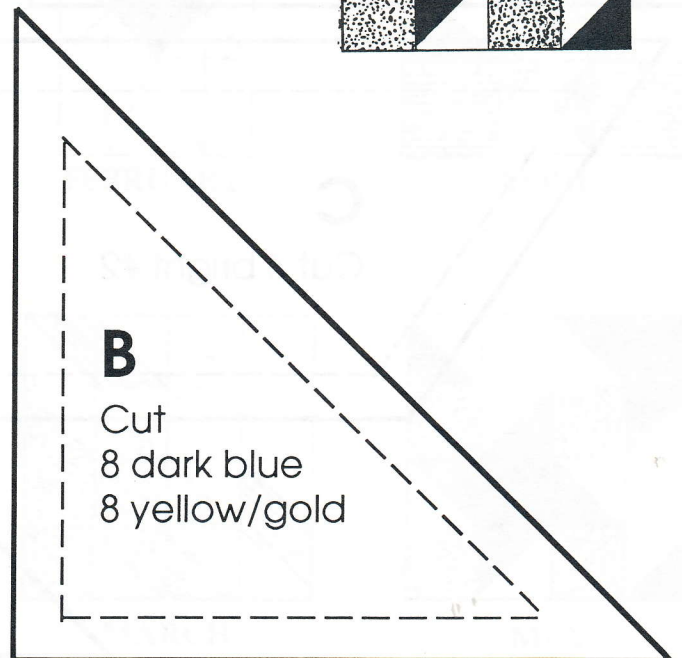
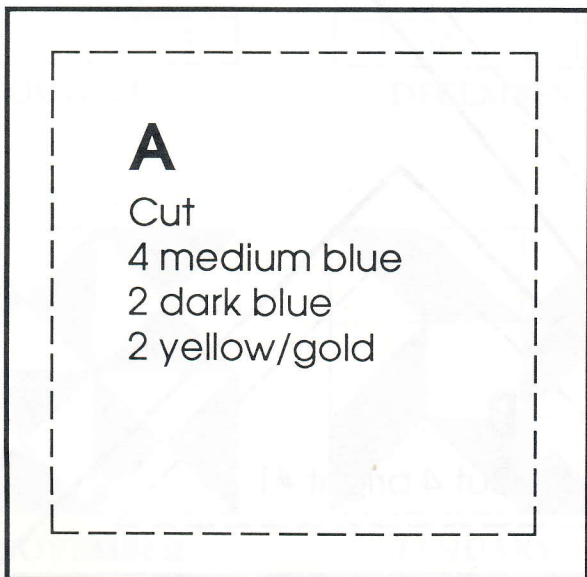
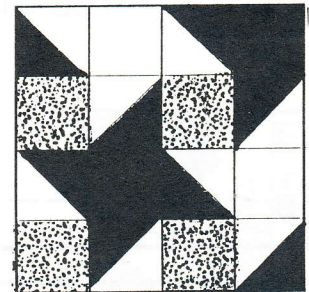

APRIL - Rock 'n Roll Star

We've included a different kind of star for your consideration in April. Let your color choices dazzle on the black and gray just like the rock 'n roll stars dazzle on stage. Finished size is 9" square.

Quick Cut Method

- A - Cut (4) $3\frac{1}{2}$ " squares of gray
Cut (1) $3\frac{1}{2}$ " square of bright #1
- B - Cut (1) $4\frac{1}{4}$ " square of gray
Cut (1) $4\frac{1}{4}$ " square of black
(cut diagonally both directions to get quarter square triangles)
- C - Use template
- D - Cut (2) $2\frac{3}{8}$ " squares of bright #1 then cut once diagonally for half-square triangles

